

# GS212IE

OPERATING INSTRUCTIONS - I



LANEY AMPLIFICATION  
[www.laney.co.uk](http://www.laney.co.uk)

**GS212IE**

# Laney

---

Dear Player,

Thank you very much for purchasing your new Laney product and becoming part of the worldwide Laney family. Each and every Laney unit is designed and built with the utmost attention to care and detail, so I trust yours will give you many years of enjoyment.

Laney products have a heritage which stretches back to 1967 when I first began building valve amplifiers in my parent's garage. Since then we have moved on from strength to strength developing an extensive range of guitar, bass, public address and keyboard amplification products along with a list of Laney endorsees that includes some of the world's most famous and respected musicians. At the same time we believe we have not lost sight of the reason Laney was founded in the first place - a dedication to building great sounding amplification for working musicians.

Warm Regards,



Lyndon Laney CEO

## INTRODUCTION

The GS212IE is a 2 x 12" cabinet rated at 160 watts (8 ohms) and can be used in isolation or combined with other Laney enclosures.

Construction features a robust plywood cabinet, with large top mounted 90 degree side bar handles, castor cups, switchable impedance and a choice of Mono or Stereo modes.

Every Laney product is extensively play tested by experienced guitarists to ensure it has the tone and durability to perform at the very highest level, before being shipped to our customers.

Your GS212IE should give you years of trouble-free service, however please take time to read this manual, as it will allow you to get the best from your extension cabinet. We hope you enjoy using your GS212IE as much as we enjoyed designing and making it.

Best wishes from all at Laney.

SPECIFICATIONS	GS212IE
Impedance	Switchable Impedance
Loudspeaker	2 x 12" Celestion 70/Eighty
Power Rating	Mono 160W RMS Stereo 2*80W RMS
Size W*D*H	715*358*455
Weight	20 Kg

Always use good quality speaker cables

INPUT	IMPEDANCE	M/S SWITCH	OPERATES
A	4 Ohms	Mono	All Speakers
B	16 Ohms	Mono	All Speakers
A	8 Ohms	Stereo	RH Half of Cab
B	8 Ohms	Stereo	LH Half of Cab

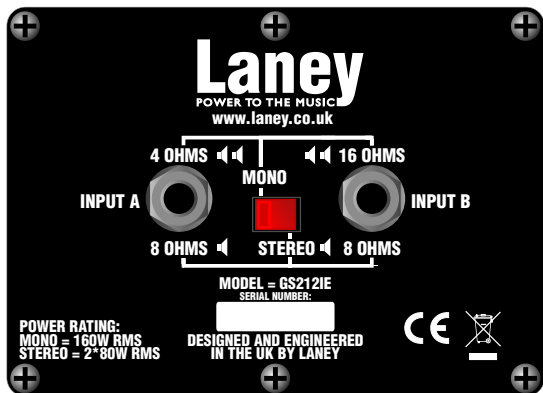

# Laney

System using  
1\* LC15-110  
1\* GS212IE

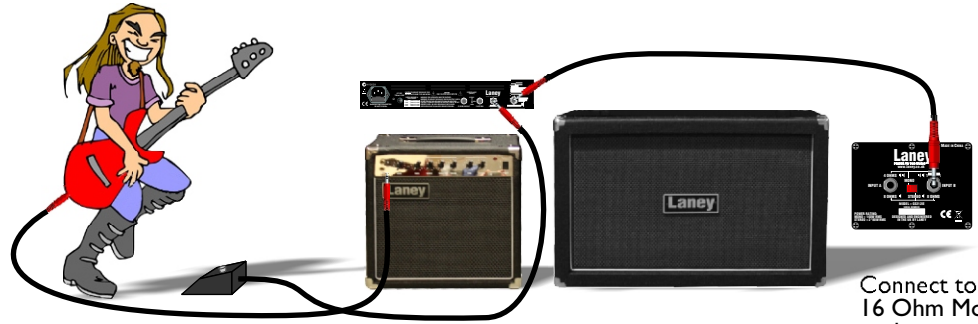

Connect to the  
16 Ohm Mono  
socket.

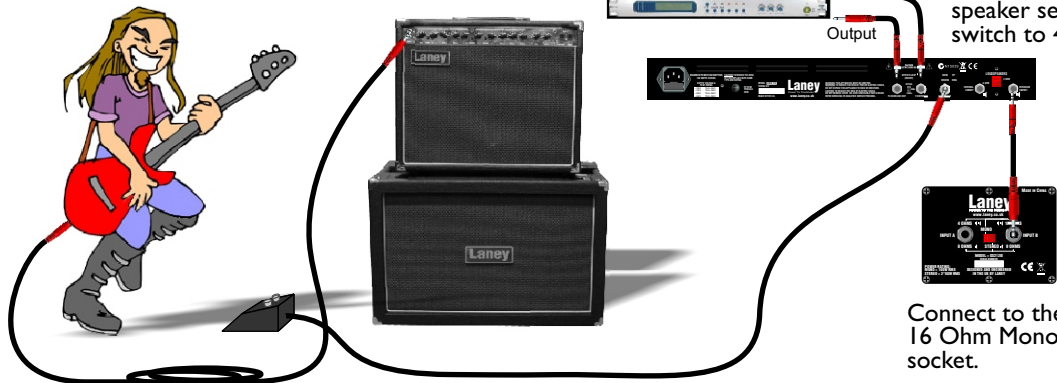

Connect to the Extension Cab.  
socket, if also using the internal  
speaker set impedance  
switch to 4 Ohms.

System using  
1\* LC50-112  
1\* GS212IE  
& FX Controller

Connect to the  
16 Ohm Mono  
socket.

SAMPLE SYSTEMS

Stereo system using  
 2\* GH50L Heads  
 1\* GS212IE  
 & FX Controller

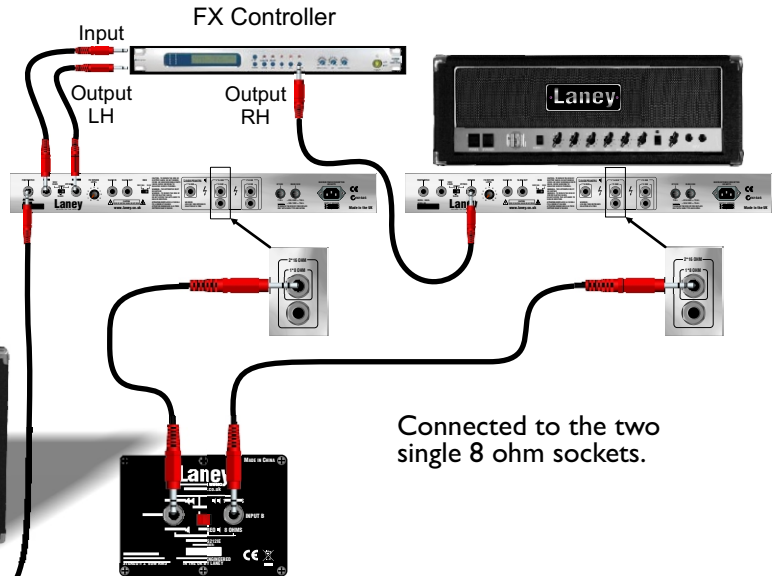
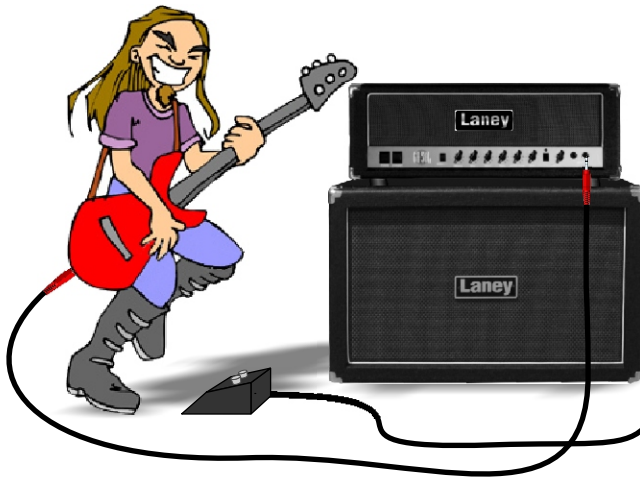

Connected to the two single 8 ohm sockets.

# Laney

System using  
 1\* VH100R Head  
 1\* GS212IE  
 1\* GS412IA  
 & FX Controller

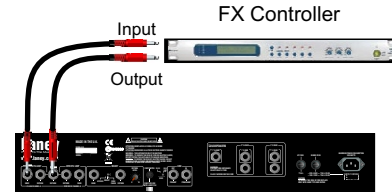

Connect to the single 8 ohm socket.



Connect to the 16 ohm Mono socket.



## IMPORTANT SAFETY INSTRUCTIONS

- 1). **Read & Retain these Instructions** carefully before installing or operating this product.
- 2). **Comply with Warnings:** All warnings and instructions for these products should be adhered to.
- 3). **Unpacking:** On unpacking your product please check carefully for any signs of damage that may have occurred whilst in transit from the Laney factory to your dealer. In the unlikely event that there has been damage, please repack your unit in its original carton and consult your dealer. We strongly advise you to keep your original transit carton, since in the unlikely event that your unit should develop a fault, you will be able to return it to your dealer for rectification securely packed.
- 4). **Amplifier Connection:** In order to avoid damage, it is advisable to establish and follow a pattern for turning on and off your system. With all system parts connected, turn on source equipment, tape decks, cd players, mixers, effects processors etc, BEFORE turning on your guitar amplifier. Many products have large transient surges at turn on and off which can cause damage to your speakers.  
By turning on your guitar amplifier LAST and making sure its level control is set to a minimum, any transients from other equipment should not reach your loud speakers. Wait till all system parts have stabilised, usually a couple of seconds. Similarly when turning off your system always turn down the level controls on your guitar amplifier and then turn off its power before turning off other equipment
- 5). **Cables:** Never use shielded or microphone cable for any speaker connections as this will not be substantial enough to handle the amplifier load and could cause damage to your complete system.
- 6). **Caution:** These professional loudspeaker systems are capable of generating very high sound pressure levels. Use care with placement and operation to avoid excessive levels that can cause permanent hearing damage.
- 7). **Exposure** to extremely high noise levels may cause a permanent hearing loss. Individuals vary considerably in susceptibility to noise induced hearing loss, but nearly everyone will lose some hearing if exposed to sufficiently intense noise for a sufficient time. The U.S. Government's Occupational Safety and Health Administration (OSHA) has specified the permissible noise level exposure in the chart opposite.  
According to OSHA, any exposure in excess of the above permissible limits could result in some hearing loss. Ear plugs or protectors in the ear canals or over the ears must be worn when operating this amplification system in order to prevent a permanent hearing loss if exposure exceeds the limits set forth opposite. To ensure against potentially dangerous exposure to high sound pressure levels it is recommended that all persons exposed to equipment capable of producing high sound pressure levels such as this amplification system be protected by hearing protectors while this unit is in operation.
- 8). **Servicing:** The user should not attempt to service these products. Refer all servicing to qualified service personnel

Duration Per Day In Hours	Sound Level dBA, slow response
8	90
6	92
4	95
3	97
2	100
1 ½	102
1	105
½	110



In order to reduce environmental damage, at the end of its useful life, this product must not be disposed of along with normal household waste to landfill sites. It must be taken to an approved recycling centre according to the recommendations of the WEEE (Waste Electrical and Electronic Equipment) directive applicable in your country.

This product conforms to the requirements of the following European Regulations, Directives & Rules:-  
 CE Mark (93/68/EEC), Low Voltage (72/23/EEC), EMC (93/68/EEC),  
 RoHS (EU2002/95/EC), WEEE (EU2002/96/EC)

**Laney**  
POWER TO THE MUSIC

LANEY AMPLIFICATION  
[www.laney.co.uk](http://www.laney.co.uk)

In the interest of continued product development, Laney reserves the right to amend product specification without prior notification.